

“Helping you put the Edge on Glass”

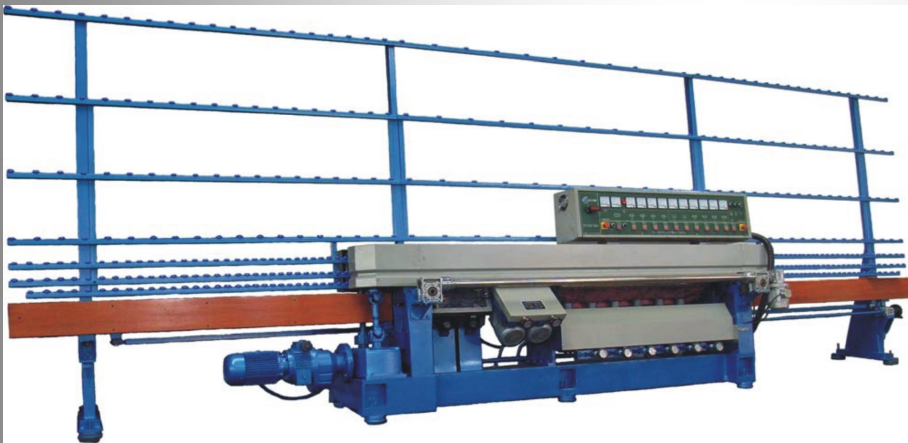

327 South Rd

High Point, NC 27262

336-373-0777



“Helping you put the Edge on Glass”

www.machinesandwheels.com



Contact Us: 1-888-383-0777

336-373-0777

mandw@machinesandwheels.com

Scottie-Owner

Garland-Technical Support/Sales

Gray-Technical Support/Sales

Heather-Sales/Technical Assistance

David Collins-Sales

Lisa-Accounting

327 South Rd

High Point, NC 27262

336-373-0777



“Helping you put the Edge on Glass”

www.machinesandwheels.com

About Machines and Wheels

- ◆ **Machines and Wheels was established in 1982 by Scott and Hannelore Bushell. After Scott's passing, Hannelore continued to run the business for as long as possible, and in 2014 she sold the business to Scottie Stephens. Scottie had been an integral member of the Machines and Wheels team for over 15 years. Scottie is not only an owner/manager, but his experience matched with his knowledge of glass machinery enables him to maintain a hands on approach with both his employees and customers.**
- ◆ **Machines and Wheels employs some of the finest, most experienced technicians in the glass industry. Our techs are known for their expertise, availability, and attention to detail.**
- ◆ **Machines and Wheels still believes in a personal approach. Our customer service is unparalleled, and our number one priority is customer satisfaction.**
- ◆ **In addition to our glass machinery and consumables, Machines and Wheels also offers parts, service and repairs for any type of glass machinery.**

327 South Rd

High Point, NC 27262

336-373-0777



"Helping you put the Edge on Glass"

www.machinesandwheels.com

topDRILL 130 Easy

The topDrill 130 Easy is the established starter model for double sided semi-automatic glass drilling machines.

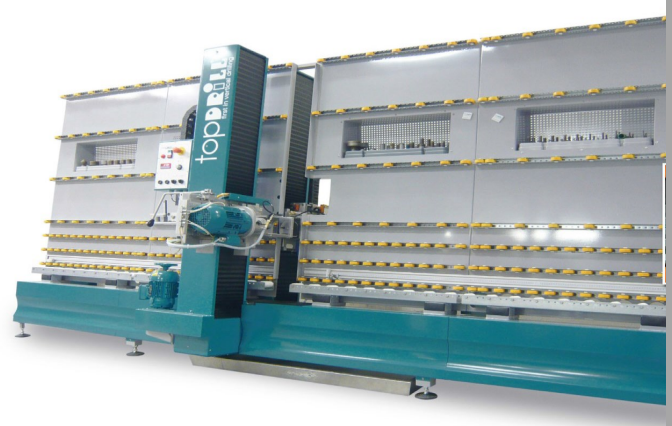

Advantages

- ◆ Machine weight is 1500 kg/3300 lbs, Modular design
- ◆ Single lever operation for the complete drilling cycle
- ◆ Motorized height adjustment with digital display
- ◆ Electronic speed adjustment with scale
- ◆ Fixed glass support rollers, moveable drill heads
- ◆ Precision linear guides for drilling head movements
- ◆ Maximum drilling diameter: 100mm with no problems
- ◆ Easy setting without marking or laser
- ◆ Combinations with diamond saw or washing machine

Foldaway Length Stop



Motorized Height Adjustment



Quick Change System



Rd

High Point, NC 27262

“Helping you put the Edge on Glass” 336-373-0777

www.machinesandwheels.com

topDRILL M-RX 130

Advantages



- ◆ New Vacuum system to hold the rear side of the glass
- ◆ Dynamic vacuum control detects holes or cut-outs
- ◆ Automatic speed adjustment of the feed-rate
- ◆ Automatic tool assignment with possibility of favorites
- ◆ Automatic in and out movement at inner cut-outs
- ◆ Automatic milling access hole for special or inner cutouts
- ◆ Holes and deep countersinking on both sides without loss of cycle time
- ◆ Laminated glass drilling mode as standard for glass thickness up to 40mm
- ◆ Low maintenance due to long-proven components
- ◆ Operation easily possible without knowledge of CNC
- ◆ No restriction of milling in size and shape
- ◆ Dynamic tool change while processing
- ◆ Open to construction, allows no limit on glass height

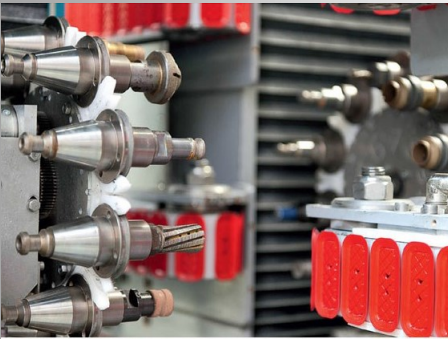

Drilling, countersinking, milling and grinding without limit in dimension and shape



327 South Rd

High Point, NC 27262

336-373-0777

topDRILL 130 RX smart-5



The topDRILL 130 RX smart-5 with its' fast and ingenious tool changer, relatively simple and uncomplicated operation is one of the best-selling devices for the entire series

Advantages

- ◆ Drilling and countersinking with absolute precision in one clamping
- ◆ Design open top, no limit of the glass dimensions
- ◆ Torque Control for deep countersinking without glass breakage
- ◆ Water-cooled high performance spindles, each with 5.5kW
- ◆ Dynamic tool change while processing
- ◆ Drilling diameter up to 80mm, glass thickness up to 40mm
- ◆ Program preselection and laminated glass mode standard
- ◆ Job overview with tool preview



Tools are Always Ready for Drilling



Waterproof and Easily Accessible



Operator Panel Foldaway for Optimum View



Type: ZS 150-M Super Compact

The new generation of compact and reliable water centrifuges



Advantages

- ◆ Uses no wearable parts of flocculants/filter agents
- ◆ No longer necessary to clean or chisel out the circulation tank
- ◆ No pipe blockages caused by deposits of dirt
- ◆ No additional installation or servicing costs. Easily operated.
- ◆ Increases operational life of both the grinding wheels and grinding machine
- ◆ Easy to handle and reliable use

New: includes vibration sensor against possible overload

327 South Rd

High Point, NC 27262

336-373-0777



“Helping you put the Edge on Glass”

www.machinesandwheels.com

M&W **Ultra** Series SAE10M

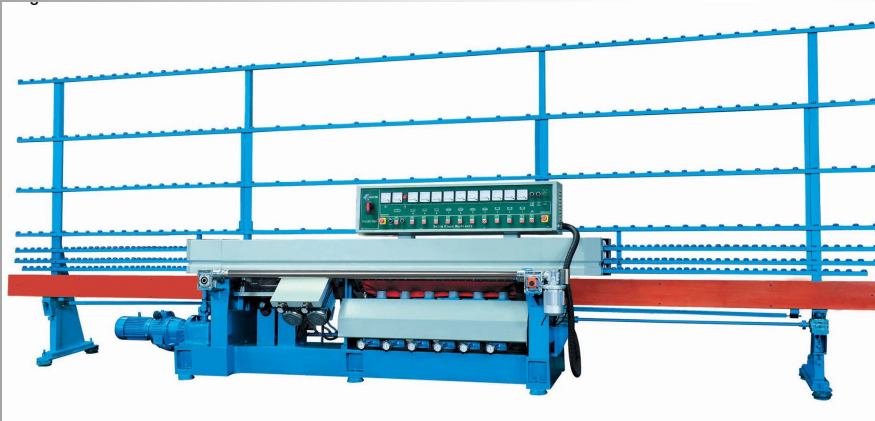

The M&W **Ultra** Series SAE10M is a 10 spindle variable angle mitering machine, with 2 diamond, 2 resin and 2 polishing spindles on a 0-45° mitering base and 4 spindles for the front and rear aris. The glass thickness is adjusted by turning a knob on the control panel and displayed on a scale meter. The mitering angle is adjusted by turning a knob on the control panel and the

angle is indicated on a scale disc. The conveyor speed is manually controlled with the hand-wheel of a stepless reducer with high to low speed range. Glass removal is regulated by adjusting a hand-wheel on the input conveyor. Inlet and outlet conveyors use timing belts for long life and precise operation.

Characteristics:

Power requirement:	as per customer request
Glass thickness: (1/8" -1)	3-26mm
Minimum glass size:	120mm (4 3/4")
Mitering Angle:	0-45°
Conveyor speed: min (19"-137"/min)	0.5-3.5 m/
Inlet conveyor height:	880mm (335")
Total weight:	3500kg (7,716 lbs)
Length:	6900mm (272")
Width: (47.25")	1200mm
Height:	2800mm (110.25")

Advantages

- ◆ Angle of edge can be changed from 0-45 degrees
- ◆ Grinding and polishing of angle, flat edge, and aris are finished in one processing
- ◆ Timing belt for the input and output conveyor to improve the precision of transmission
- ◆ Mechanical stepless reducer for adjusting the glass feeding speed, quick and easy for different sizes and thicknesses of glass
- ◆ Digital meter displays glass thickness

327 South Rd

High Point, NC 27262

336-373-0777



"Helping you put the Edge on Glass"

www.machinesandwheels.com

M&W **Ultra** Series SE5M



The M&W Ultra Series SE5M is a straight line flat edging machine with 5 spindles capable of producing flat and flat with arris profiles. Beginning with 1 cup diamond wheel, the configuration is followed by 2 45° arrising wheels (front and back arris), then followed by 1 cup polishing wheel for polishing of the flat edge and 1 cerium impregnated wheel in the final position for a more brilliant polish. Inlet and outlet conveyors use timing belts for long life and precise operation, and the machine features a lubrication system for the front and rear conveyor rails. A mechanical stepless reducer adjusts the conveyor speed, and the glass thickness is changed easily by simply changing the front arris wheel position.

Characteristics:

Power requirement:	as per customer request
Glass thickness:	3-12 mm (1/8" - 1/2")
Minimum glass size:	100 mm x 100 mm (4"x4")
Conveyor speed:	0.5 - 3 m/min (19"-118" / min)
Total weight:	2000 kg (4,409 lbs)
Length:	6500 mm (256")
Width:	1200 mm (47.25")
Height:	2500 mm (110.25")

327 South Rd

High Point, NC 27262

336-373-0777

STEFIGLASS Washer

The Stefiglass Sprint Vertical Washer is suitable for heavy duty post processing washes, sandblasting, etc., and made exclusively in “open” version allowing to wash out format.

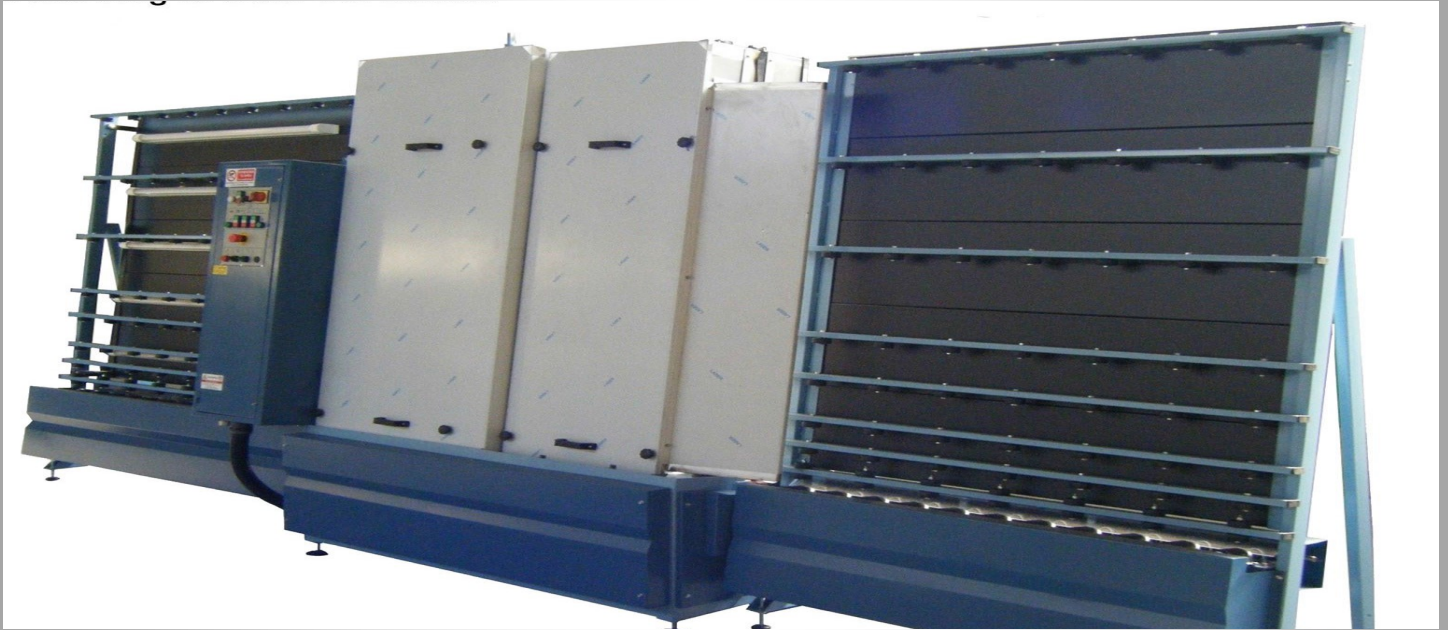

Advantages

- ◆ Glass washing minimum:300(L)x150(H)
- ◆ Features a wash/rinse area completely in stainless steel followed by a large drying area
- ◆ Both areas of the machine are accessible through removable casing, soundproof in drying area
- ◆ The mechanical movement is placed at the bottom, below the crankcase
- ◆ Working speed: 1 to 5 minutes

Products and Services

Diamond Grinding Wheels

Machines and Wheels supplies a variety of grinding products to be suited for particular machine applications. In order to satisfy customer needs, we take in to account what the customer is looking for combined with the capabilities of their equipment. Every factor counts, and every factor comes in to play when it comes to Machines and Wheels providing you with optimum performance and the best cost.

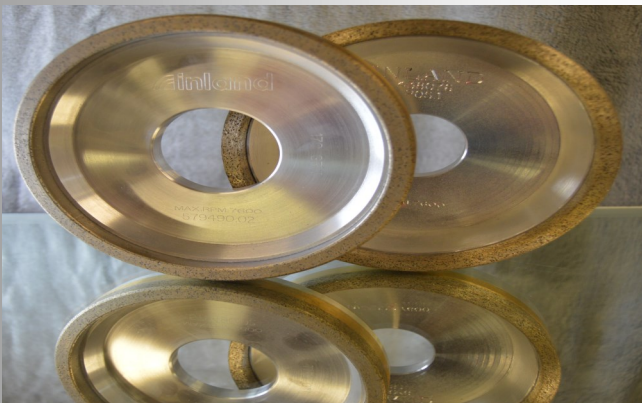

Decorative profile wheels

Decorative profile wheels need to be precisely formed and need to retain that form as long as possible in order to provide a uniform edge on the glass. Machines and Wheels has developed a wide range of decorative profile specifications in conjunction with our suppliers, taking into account esthetic considerations as well as the demand of ease of cut and polish. In addition, Machines and Wheels offers a pre-profiling service for polishing wheels in order to facilitate break-in of decorative profile polishing wheels.

Machines and Wheels Retruing Service

Machines and Wheels offers a diamond wheel retruing service to extend the optimal usefulness of your diamond wheel products. Over time wheels can become misshapen, or can develop off center grooves that create an uneven finish. V-groove or D-groove wheels can flatten out. They may need to be opened up to restore the cutting.



High Point, NC 27262



“Helping you put the Edge on Glass” 336-373-0777

www.machinesandwheels.com

Products and Services

Long-Life Diamond Drill Bits

Bonded diamond drill bits are made with a 10 mm deep sintered diamond crown. Unlike electroplated bits, where a single layer of diamonds is coated onto a steel tube, the bonded bit wears uniformly throughout the depth of the bond, giving a life expectancy of 30 times that of the electroplated bit. We have a wide variety of sizes available with the following configurations: Straight shank (3/8") bits for tripod and drills with a standard chuck and 1/2" threaded Belgium mount in both short (75mm) and long (95mm) configurations.

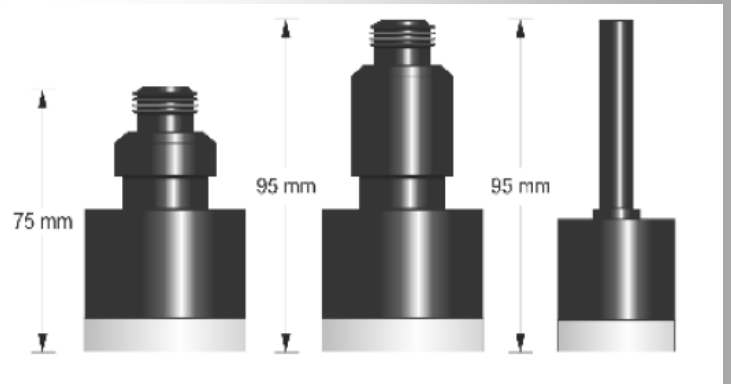

"Helping you put the Edge on Glass"

www.machinesandwheels.com

327 South Rd

High Point, NC 27262

336-373-0777

Cerium Oxide

Machines and Wheels offers cerium oxide for your scrubbing and polishing needs. Cerium oxide polishing compounds are manufactured with a certain percentage of cerium oxide along with enhancing additives such as suspension and dispersion agents. In general, higher grades contain the higher percentages of cerium oxide. Machines and Wheels offers three types of cerium depending on your application.



“Helping you put the Edge on Glass”

www.machinesandwheels.com

327 South Rd

High Point, NC 27262

336-373-0777

Machines and Wheels

Ultra Series Edger Wheel Diagrams



“Helping you put the Edge on Glass”

www.machinesandwheels.com

327 South Rd

High Point, NC 27262

336-373-0777

Machines and Wheels **Ultra** Series SAE10M

<u>Position</u>	<u>Description</u>	<u>Part Number</u>
1	Diamond Segmented	DWSUN6FE50BSW
2	Diamond Solid Band	DWSUN6FE50D
3	Diamond Res/Met Bond	DWSUN6FE50REPK
4	Diamond Res/Met Bond	DWSUN6FE50RMPK
5	150x40x70 10S-80	PC10S-1504070-80
6	150x40x70 CE-3 Cerium Artifex	PCEX-1504070-C
7	Diamond Res/Met Arris	DWSUN5AW50RMPK
8	130X35X60 AR2	PCAR2-130X35X60
9	Diamond Res/Met Arris	DWSUN5AW50RMPK
10	130X35X60 AR2	PCAR2-130X35X60

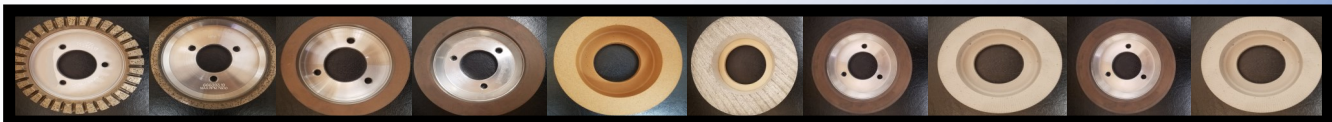

327 South Rd

High Point, NC 27262

336-373-0777



“Helping you put the Edge on Glass”

www.machinesandwheels.com

Machines and Wheels **Ultra** Series SE9M

<u>Position</u>	<u>Description</u>	<u>Part Number</u>
1	Diamond Solid Band	DWSUN6FE50D
2	Diamond Solid Band	DWSUN6FE50MF
3	Diamond Res/Met Bond	DWSUN130AW50RMPK
4	130x35x60 AR2	PCAR2-1303560
5	Diamond Res/Met Bond	DWSUN130AW50RMPK
6	130x35x60 AR2	PCAR2-1303560
7	Diamond Res/Met	DWSUN6FE50RTPI
8	150x40x70 10S-80	PC10S-1504070-80
9	150x40x70 CE-3 Cerium Artifex	PCFEX-1504070-C



“Helping you put the Edge on Glass”

www.machinesandwheels.com

327 South Rd

High Point, NC 27262

336-373-0777

Machines and Wheels **Ultra** Series SE5M

<u>Position</u>	<u>Description</u>	<u>Part Number</u>
1	Diamond Solid Band	DWSUN6FE50E
2	Diamond Resin Arris	DWCHA125AW50RQPK
3	Diamond Resin Arris	DWCHA125AW50RQPK
4	150x30x70-60	PCAA-1503070-60
5	150x40x70 Cerium Rubber	PCWR-1504070-C



327 South Rd

High Point, NC 27262

"Helping you put the Edge on Glass" 336-373-0777

www.machinesandwheels.com

Machines and Wheels Shape Edgers by Metral



“Helping you put the Edge on Glass”

www.machinesandwheels.com

327 South Rd

High Point, NC 27262

336-373-0777

Machine: Metral CMG/FNG

Description: Shape Beveller/Edger

Pos	Part #	Description
1	DWMET4PE22EF5	1/4 PE one-step
2	PPBD-1001522	100x15x22 polish
1	DWMET4PE22EF8	3/8 PE one-step
2	PPBD-1002022	100x20x22 polish
1	DWMET4PE22EF10	1/2 PE one-step
2	PPBD-1002522	100x25x22 polish
1	DWMET4FS22EF5	1/4 F/S one-step
2	PPBD-1001522	100x15x22 polish
1	DWMET4FS22EF8	3/8 FS one-step
2	PPBD-1002022	100x20x22 polish
1	DWMET4FS22EF10	1/2 F/S one-step
2	PPBD-1002522	100x25x22 polish

Bevelling

1	DWMET6BV30MB	150mm Metal
2	DWMET6BV30RFPI	150mm Resin
3	DWMET6BV30RQPI	150mm Resin

Decorative profiles also available: OG, Waterfall etc.



“Helping you put the Edge on Glass”

www.machinesandwheels.com

327 South Rd

High Point, NC 27262

336-373-0777

Machines and Wheels

Ultra Series Bevellers



“Helping you put the Edge on Glass”

www.machinesandwheels.com

327 South Rd

High Point, NC 27262

336-373-0777

Machine: Machines and Wheels **Ultra** Series 371B

Description: Straight Line Beveller

Post	Part #	Description
1	DWCHA6BVM1	Diamond Metal Bond
2	DWCHA6BVM2	Diamond Metal Bond
3	DWCHA6BVR3PI	Diamond Resin Bond
4	DWCHA6PE22EF5	150mm Diamond One Step PE
5	DWCHA6BVR4PI	Diamond Resin Bond
6	DWCHA6BVR5PI	Diamond Resin Bond
7	DWCHA6BVR6PI	Diamond Resin Bond
8	DWCHA6BVR7PI	Diamond Resin Bond
9	PCSF-1502570	150x25x70 Synthetic Felt
10	PCSF-18525114.3	185x25x114.3 Synthetic Felt
11	PCSF-1502570	150x25x70 Synthetic Felt



“Helping you put the Edge on Glass”

www.machinesandwheels.com

327 South Rd

High Point, NC 27262

336-373-0777

Machine: Machines and Wheels **Ultra** Series 351B

Description: Straight Line Beveller

Pos	Part #	Description
1	DWCHA6BVM1	Diamond Metal Bond
2	DWCHA6BVM2	Diamond Metal Bond
3	DWCHA6PE22EF5	150mm Diamond PE One Step
4	DWCHA6BVR4PI	Diamond Resin Bond
5	DWCHA6BVR5PI	Diamond Resin Bond
6	DWCHA6BVR6PI	Diamond Resin Bond
7	PCSF-1502570	150x25x70 Synthetic Felt
8	PCSF-18525114.3	185x25x114.3 Synthetic Felt
9	PCSF-1502570	150x25x70 Synthetic Felt



"Helping you put the Edge on Glass"

www.machinesandwheels.com

327 South Rd

High Point, NC 27262

336-373-0777

Bavelloni Machinery



“Helping you put the Edge on Glass”

www.machinesandwheels.com

327 South Rd

High Point, NC 27262

336-373-0777

Machine: Bavelloni B73 / B75

Description: Straight Line Beveller

Pos	Part #	Description
1	DWBAV6BVM1I	Diamond Metal Bond
2	DWBAV6BVM2I	Diamond Metal Bond
3	DWBAVB73TUR3PI	Diamond Resin Bond
4	DWBAVB73TUR4PI	Diamond Resin Bond
5	DWBAV7PE90M5	Diamond Metal Bond ¼" PE
6	PCSF-1504070	Spiral Synthetic Felt
7	PCSF-1504070	Spiral Synthetic Felt



“Helping you put the Edge on Glass”

www.machinesandwheels.com

327 South Rd

High Point, NC 27262

336-373-0777

Machine: Bavelloni CR1111

Description: Straight Line Edger

Pos	Part #	Description
1	DWBAV6FE11B	Diamond Solid Band 100
2	DWBAV6FE11D	Diamond Solid Band 140
3	DWBAV6FE11M	Diamond Solid Band 230
4	DWBAV4AW11F	Diamond Arris 200/230
5	PCMB2-1002540-J40	Resin Polish
6	DWBAV4AW11F	Diamond Arris 200/230
7	PCMB2-1002540-J40	Resin Polish
8	PC10S-15040J40-40	150x40 J-40 10S40
9	PC10S-15040J40-60	150x40 J-40 10S60
10	PC10S-15040J40-80	150x40 J-40 10S80
11	PCX-1503070-C	150x30 J40 X3000



“Helping you put the Edge on Glass”

www.machinesandwheels.com

327 South Rd

High Point, NC 27262

336-373-0777

Machine: Bavelloni GEMY 11

Description: Straight Line Edger

Pos	Part #	Description
1	DWBAV6FE11C	Diamond Solid Band 120
2	DWBAV6FE11D	Diamond Solid Band 140
3	DWBAV6FE11M	Diamond Solid Band 230
4	DWBAV6AW11RVPK	Resin Arris 325/400
5	DWBAV6AW11RVPK	Resin Arris 325/400
6	PCMB2-1504070	150x40 J-40 Resin Polish
7	PCMB2-1504070	150x40 J-40 Resin Polish
8	PC10S-15040J40-40	150x40 J-40 10S40
9	PC10S-15040J40-60	150x40 J-40 10S60
10	PCX3-1503070-C	150x40 J-40 X3000 Cerium
11	PCSF-1504070	Spiral Synthetic Felt



“Helping you put the Edge on Glass”

www.machinesandwheels.com

327 South Rd

High Point, NC 27262

336-373-0777

Machine: Bavelloni Gemy V10

Description: Straight Line Mitering / Edger

Pos	Part #	Description
1	DWBAV6FE11MBSW	Diamond Segmented 100
2	DWBAV6FE11D	Diamond Solid Band 140
3	DWBAV6FE11M	Diamond Solid Band 230
4	PC10S-15040J40-40	150X40 J-40 40 grit
5	PC10S-15040J40-60	150X40 J-40 60 grit
6	PCX3-1503070-C	150x40 J-40 X3000 Cerium
7	DWBAV6AW11RTPK	Resin Arris 270
8	DWBAV6AW11RTPK	Resin Arris 270
9	PCMB2-15040-J40	150x40 Resin Polish
10	PCMB2-15040-J40	150x40 Resin Polish



“Helping you put the Edge on Glass”

www.machinesandwheels.com

327 South Rd

High Point, NC 27262

336-373-0777

Machine: Bavelloni Gemy V14

Description: Straight Line Mitering / Edger

Pos	Part #	Description
1	DWBAV6FE11D	Diamond Solid Band 140
2	DWBAV6FE11M	Diamond Solid Band 230
3	DWBAV6FE11MBSW	Diamond Segmented 100
4	DWBAV6FE11D	Diamond Solid Band 140
5	DWBAV6FE11M	Diamond Solid Band 230
6	PC10S-15040J40-40	150x40 J-40 40 grit
7	PC10S-15040J40-60	150x40 J-40 60 grit
8	PCX3-1503070-C	150x40 J-40 X3000 Cerium
9	DWBAV6AW11RTPK	Resin Arris 270 grit
10	DWBAV6AW11RTPK	Resin Arris 270 grit
11	PCMB2-15040J40	150x40 J40 Resin polish
12	PCMB2-15040J40	150x40 J40 Resin polish
13	PC10S-15040J40-60	150x40 J-40 60 grit
14	PCX3-1503070-C	150x40 J-40 X3000 Cerium



“Helping you put the Edge on Glass”

www.machinesandwheels.com

327 South Rd

High Point, NC 27262

336-373-0777

Machine: Bavelloni GEMY 6

Description: Straight Line Edger

Pos	Part #	Description
1	DWBAV6FE11D	Diamond Solid Band 140
2	DWBAV6FE11M	Diamond Solid Band 230
3	PCMB1-1504070-J40	150x40 J-40 Resin Polish
4	PCMB1-1504070-J40	150x40 J-40 Resin Polish
5	PC10S-15040J40-40	150x40 J-40 40 grit
6	PCX3-1503070	150x40 J-40 X3000 Cerium



"Helping you put the Edge on Glass"

www.machinesandwheels.com

327 South Rd

High Point, NC 27262

336-373-0777

Machine: Bavelloni GEMY 8

Description: Straight Line Edger

Pos	Part #	Description
1	DWBAV6FE11E	Diamond Solid Band 170
2	DWBAV6FE11M	Diamond Solid Band 230
3	DWBAV6AW11RVPK	Resin Arris 325/400
4	DWBAV6AW11RVPK	Resin Arris 325/400
5	PCMB2-15040-J40	150x40 J-40 Resin Polish
6	PCMB2-15040-J40	150x40 J-40 Resin Polish
7	PC10S-15040J40-60	150x40 J-40 10S 60
8	PCX3-1503070-C	150x40 J-40 X3000 Cerium



“Helping you put the Edge on Glass”

www.machinesandwheels.com

327 South Rd

High Point, NC 27262

336-373-0777

Machine: Bavelloni MAX 50 TMS

Description: Straight Line Beveller

Pos	Part #	Description
1	DWBAV6BVM1	Diamond Metal Bond
2	DWBAV6BVM2	Diamond Metal Bond
3	DWBAV6BVR3PI	Diamond Resin Bond
4	DWBAV6BVR4PI	Diamond Resin Bond
5	DWBAV6BVR5PI	Diamond Resin Bond
6	DWBAV6BVR6PI	Diamond Resin Bond
7	DWBAV4AW11RTPK	Resin Arris 270 Grit
8	PCSF-1504070	Spiral Synthetic Felt
9	PCSF-1504070	Spiral Synthetic Felt
10	PCSF-1504070	Spiral Synthetic Felt
11	DWBAV7PEBVF5	Diamond ¼" PE 200
12	PPAA-2002090-180	200x20x90 180 Grit



"Helping you put the Edge on Glass"

www.machinesandwheels.com

327 South Rd

High Point, NC 27262

336-373-0777

Machine: Bavelloni MAX60 CNS

Description: Straight Line Beveller

Pos	Part#	Description
1	DWBAV6BVM1	Diamond Metal Bond
2	DWBAV6BVM2	Diamond Metal Bond
3	DWBAV6BVR3PI	Diamond Resin Bond
4	DWBAV6BVR4PI	Diamond Resin Bond
5	DWBAV6BVR5PI	Diamond Resin Bond
6	DWBAV6BVR6PI	Diamond Resin Bond
7	DWBAV4AW11RTPK	Resin Arris 270 Grit
8	PCSF-1504070	Spiral Synthetic Felt
9	PCSF-1504070	Spiral Synthetic Felt
10	PCSF-1504070	Spiral Synthetic Felt
11	DWBAV7PEBVF5	Diamond ¼" PE 200
12	PPAA-2002090-180	200x20x90 180 Grit

327 South Rd

High Point, NC 27262

336-373-0777



"Helping you put the Edge on Glass"

www.machinesandwheels.com

Machine: Bavelloni MAX80 CNS

Description: Straight Line Beveller

POS	Part #	Description
1	DWBAV6BVM1	Diamond Metal Bond
2	DWBAV6BVM2	Diamond Metal Bond
3	DWBAV6BVR3PI	Diamond Resin Bond
4	DWBAV6BVR4PI	Diamond Resin Bond
5	DWBAV6BVR5PI	Diamond Resin Bond
6	DWBAV6BVR6PI	Diamond Resin Bond
7	DWBAV4AW11RTPK	Resin Arris 270 Grit
8	PCSF-1504070	Spiral Synthetic Felt
9	PCSF-1504070	Spiral Synthetic Felt
10	PCSF-1504070	Spiral Synthetic Felt
11	DWBAV7PEBVF5	Diamond ¼" PE 200
12	PPAA-2002090-180	200x20x90 180 Grit



"Helping you put the Edge on Glass"

www.machinesandwheels.com

327 South Rd

High Point, NC 27262

336-373-0777

Machine: Bavelloni PR 88

Description: Straight Line Edger

Pos	Part #	Description
1	DWBAV6FE11D	Diamond Solid Band 140
2	DWBAV6FE11M	Diamond Solid Band 230
3	DWBAV4AW11F	Diamond Arris 200/230 Grit
4	PCMB2-1002540-J40	Resin Polish
5	DWBAV4AW11F	Diamond Arris 200/230 Grit
6	PCMB2-1002540-J40	Resin Polish
7	PC10S-15040J40-60	150x40 J40 60 grit
8	PCX3-1503070-C	150x40 J40 X3000 Cerium



"Helping you put the Edge on Glass"

www.machinesandwheels.com

327 South Rd

High Point, NC 27262

336-373-0777

Machine: Bavelloni SB 10

Description: Shape Beveller/Edger

Pos	Part #	Description
1	DWMET6PE22EF5	1/4 PE one-step
2	PPBD-1501522	150x15x22 polish
1	DWMET6PE22EF8	3/8 PE one-step
2	PPBD-1502022	150x20x22 polish
1	DWMET6PE22EF10	1/2 PE one-step
2	PPBD-1502522	150x25x22 polish
1	DWMET6FS22EF5	1/4 F/S one-step
2	PPBD-1501522	150x15x22 polish
1	DWMET6FS22EF8	3/8 FS one-step
2	PPBD-1502022	150x20x22 polish
1	DWMET6FS22EF10	1/2 F/S one-step
2	PPBD-1502522	150x25x22 polish

Bevelling

1	DWBAV6SB11MB	150mm Metal
2	DWBAV6SB11RFPI	150mm Resin
3	DWBAV6SB11RQPI	150mm Resin



“Helping you put the Edge on Glass”

www.machinesandwheels.com

327 South Rd

High Point, NC 27262

336-373-0777

Machine: Bavelloni TM4

Description: Straight Line Edger

Pos	Part #	Description
1	DWBAV7PE90C5	175x90 1/4" PE 120 Grit
2	DWBAV7PE90M5	175x90 1/4" PE 230 Grit
1	DWBAV7PE90B8	175x90 3/8" PE 100 Grit
2	DWBAV7PE90M8	175x90 3/8" PE 230 Grit
1	DWBAV7PE90B10	175x90 1/2" PE 100 Grit
2	DWBAV7PE90M10	175x90 1/2" PE 230 Grit
1	DWBAV7FS90D5	175x90 1/4" FS 140 Grit
2	DWBAV7FS90M5	175x90 1/4" FS 230 Grit
1	DWBAV7FS90C8	175x90 3/8" FS 120 Grit
2	DWBAV7FS90M8	175x90 3/8" FS 230 Grit
1	DWBAV7FS90C10	175x90 1/2" FS 120 Grit
2	DWBAV7FS90M10	175x90 1/2" FS 230 Grit
3	PPAA-2002090-120	200x20x90 120 Grit
4	PPAA-2002090-180	200x20x90 180 Grit



"Helping you put the Edge on Glass"

www.machinesandwheels.com

327 South Rd

High Point, NC 27262

336-373-0777

Besana Equipment



“Helping you put the Edge on Glass”

www.machinesandwheels.com

327 South Rd

High Point, NC 27262

336-373-0777

Besana R-11TS

Pos.	PART NUMBER	DESCRIPTION
1	BES6FE25MBSW	150MM SUPERTURBO OUTER WHEEL 100 GRIT
1	BES115FE25C1	115MM INNER WHEEL 120 GRIT
1	BES6FE25B	150MM CONTINUOUS RIM METAL 100 GRIT
2	BES6FE25D	150MM CONTINUOUS RIM METAL 140 GRIT
3	BES6FE25M	150MM CONTINUOUS RIM METAL 230 GRIT
4	BES125AW25T	125MM METAL ARRIS 270 GRIT
4	BES120AWRQPK	120MM RES-MET ARRIS 500 GRIT ALTERNATE
5	POL1254025BDL	125MM BD POLISH WHEEL
6	BES125AW25T	125MM METAL ARRIS 270 GRIT
6	BES120AWRQPK	120MM RES-MET ARRIS 500 GRIT ALTERNATE
7	POL1254025BDL	125MM BD POLISH WHEEL
8	BES6FE25R4PI	150 X 20 CONTINUOUS RIM RESIN 270 GRIT
9	BES6FE25R5PI	150 X 20 CONTINUOUS RIM RESIN 500 GRIT
10	BES6FE25R5PI	150 X 20 CONTINUOUS RIM RESIN 500 GRIT
11	POL1504025X5000	150 X 40 X 25 X5000 CERIUM POLISH
11	FITINL06401	150 X 25MM ALUMINUM MOUNTING PLATE



“Helping you put the Edge on Glass”

www.machinesandwheels.com

High Point, NC 27262

336-373-0777

Bovone Equipment



“Helping you put the Edge on Glass”

www.machinesandwheels.com

327 South Rd

High Point, NC 27262

336-373-0777

Machine: BOVONE ELB 10

Description: Straight Line Edger

Pos.	Part #	Description
1	BOV6FE22B	DIAMOND WHEEL 150 X 8 X 8 METAL CUP 100/120
2	BOV6FE22E	DIAMOND WHEEL 150 X 8 X 8 METAL CUP 170/200
3	BOV6FE22RF PIWSH	DIAMOND WHEEL 150 X 30 TURBO RESIN FE CUP 200 GRIT
4	BOV6AW22R TPK	DIAMOND WHEEL 150 X 20 X 10 RES-MET ARRIS 270 GRIT
5	Call with wheels size	
6	BOV6FE22RT PK	DIAMOND WHEEL 150 X 20 X 10 RES-MET ARRIS 270 GRIT
7	call with wheel size	
8	BOV6FE22RT PIWSH	DIAMOND WHEEL 150 X 30 TURBO RESIN FE CUP 270 GRIT
9	BOV6FE22RR PIWSH	DIAMOND WHEEL 150 X 30 TURBO RESIN FE CUP 700 GRIT
10	BOV1504070 FTSPF	POLISH WHEEL 150 X 40 X 70 SPIRAL [TO GLUE UP]

327 South Rd

High Point, NC 27262

336-373-0777



“Helping you put the Edge on Glass”

www.machinesandwheels.com

Machine: BOVONE ELB 10-45

Description: Straight Line Mitering Machine

Pos	Part #	Description
1	DWBOV6FE22BS	150mm SEG. 100 Grit
2	DWBOV6FE22C	150mm CB 120 GRIT
3	DWBOV6FE22RFPI	150mm Resin 200 Grit
4	DWBOV6FE22RTPI	150mm Resin 270 Grit
5	DWBOV6FE22RRPI	150mm Resin 700 Grit
6	PCFEX-1504070-C	150x40x22 Cerium Rubber
7	DWBOV6FE22RMPK	150 X 20 RES-MET ARRIS 270
8	PCAR2-1503110	150x30x10 POLISH
9	DWBOV6FE22RTPK	150mm Res-Met Arris 270 Grit
10	PCAR2-1503110	150x30x10 POLISH

327 South Rd

High Point, NC 27262

336-373-0777



“Helping you put the Edge on Glass”

www.machinesandwheels.com

Machine: BOVONE ELB 14

Description: Straight Line Edger

Pos	Part #	Description
1	DWBOV6FE22B1S	150x8x8 - 100
2	DWBOV6FE22E	150x8x8 - 170
3	DWBOV6FE22RFPI	150x20x10 - 200
4	DWBOV5AW22V	150x8x8 - 325
5	DWBOV5AW22RUPI	130x20x10 - 1200
6	DWBOV5AW22V	150x8x8 - 325
7	DWBOV5AW22RUPI	150x20x10 - 1200
8	DWBOV6FE22RTPI	150x20x10 - 270
9	DWBOV6FE22RQPI	150x20x10 - 600
10	DWBOV6FE22RQPI	150x20x10 - 600
11	PCSF-1302570	130x25x70 -
12	PCSF-1302570	130x25x70
13	PCSF-1502570	150x25x70
14	PCSF-1502570	150x25x70

327 South Rd

High Point, NC 27262

336-373-0777



“Helping you put the Edge on Glass”

www.machinesandwheels.com

Machine: BOVONE ELB 14-45

Description: Straight Line Mitering Machine

Pos	Part #	Description
1	DWBOV6FE22BSW	150mm SEG. 30 DEG 100 Grit
2	DWBOV6FE22D	150mm CB 140 Grit
3	DWBOV6FE22RFPI	150mm Resin 200 Grit
4	DWBOV6FE22RTPI	150mm Resin 270 Grit
5	DWBOV6FE22RRPI	150mm Resin 700 Grit
6	PCWR-1504022-C	150x40x22 Cerium Rubber
7	DWBOV6FE22C	150mm CB 120 Grit
8	DWBOV5AW22RTPK	130mm Res-Met Arris 270 Grit
9	PC10S-1504022-80	150x40x22 10S80
10	DWBOV5AW22RTPK	130mm Res-Met Arris 270 Grit
11	PC10S-1504022-80	150x40x22 10S80
12	DWBOV6FE22RTPI	150mm Resin 270 Grit
13	DWBOV6FE22RRPI	150mm Resin 700 Grit
14	PCWR-1504022-C	150x40x22 Cerium Rubber

327 South Rd

High Point, NC 27262

336-373-0777



“Helping you put the Edge on Glass”

www.machinesandwheels.com

Machine: Bovone MiniMax 371

Description: Straight Line Beveller

Pos	Part #	Description
1	DWBOV6BVM1	Diamond Metal Bond
2	DWBOV6BVM2	Diamond Metal Bond
3	DWBOV6BVR3PI	Diamond Resin Bond
4	DWBOV95PEBV5E	95mm Diamond 1/4" PE 170
5	DWBOV6BVR4PI	Diamond Resin Bond
6	DWBOV6BVR5PI	Diamond Resin Bond
7	DWBOV6BVR6PI	Diamond Resin Bond
8	DWBOV6BVR7PI	Diamond Resin Bond
9	PCSF-1502570	150x25x70 Synthetic Felt
10	PCSF-18525114.3	185x25x114.3 Synthetic Felt
11	PCSF-1502570	150x25x70 Synthetic Felt

327 South Rd

High Point, NC 27262

336-373-0777



"Helping you put the Edge on Glass"

www.machinesandwheels.com

Polish Wheels

Machines and Wheels carries several different types of polishing wheels manufactured by established companies in the glass industry. Marrose Abrasives, RBM, Itamole, Abrasipa, and Buffalo Felt Products are industry leaders, and Machines and Wheels is proud to offer these quality wheels to their customers.

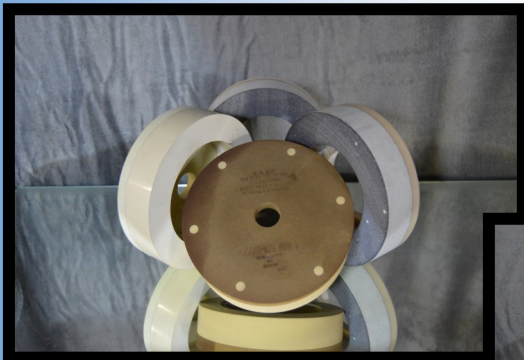

"Helping you put the Edge on Glass"

www.machinesandwheels.com

327 South Rd

High Point, NC 27262

336-373-0777

Testimonials

- ♦ “Machines and Wheels customer service exceeds ordinary expectations with round the clock attendance and a superb attitude. Heather and the office staff takes and ships orders diligently and tends to our company’s needs in a quick and timely fashion. Their wide variety of both tooling and equipment are enough to meet even the biggest shop’s most demanding requirements.”

-Link McIntosh, Safety and Maintenance American Glass Inc.
-Springfield, MO

- ♦ “We are very happy with our MRX– it has proven very reliable, simple to maintain, and we get great throughput– our operators load the conveyor, scan a label, and off it goes. The installation and the parts and service with Scottie Stephens and Gray Noah has exceeded our expectations. Machines and Wheels is the best equipment service organization we deal with, bar none.”

-John Dwyer, President, Syracuse Glass Company,
Syracuse NY



“Helping you put the Edge on Glass”

www.machinesandwheels.com

High Point, NC 27262

336-373-0777

- ◆ “In 2005, I purchased a flat edger from Machines and Wheels. The whole experience with the set up and training was fantastic. The technicians are extremely knowledgeable. Since then, any time that I have called with any question regarding troubleshooting or wheels or anything, they have been so helpful and taken the time to make sure my problem was solved. I highly recommend this company if you are considering a machine purchase.”

-Stace Overly, Owner, Westshore Glass & Mirror, Inc

- ◆ “You guys have helped me with the problems with my beveller through extensive telephone support. You guys are great– you spent time with me when you didn’t have to. I could write three pages, but to keep it short, your tech support is the best, and I will confirm it to anyone who wants to call me.”

-Don Caggiano, Owner, Action Glass Company, Massachusetts

- ◆ “Here is a sample of 3/4 we ran through the 5 spindle. We have processed several large pieces with no trouble. This was done using the special set of pads. I want you to know that we are happy with the machine and it is making us money. Thanks for all your help.”

-Chuck O., Owner, Glass Act Productions, SC



“Helping you put the Edge on Glass” 336-373-0777

www.machinesandwheels.com

High Point, NC 27262



Machines and Wheels proudly sells the finest Diamond tooling on the market. Machines and Wheels has a long standing reputation of selling premium cost effective tooling and supplies. All tooling is manufactured by the best manufacturers in the business. All tooling sold by Machines and Wheels has also been tested by the staff and customers. Machines and Wheels is committed to giving you the highest quality tooling and supplies for the most competitive price. Our manufacturers stand behind their tooling and we stand with them to ensure every customer comes away with exactly what they need to make their production easier.

327 South Rd

High Point, NC 27262

336-373-0777



“Helping you put the Edge on Glass”

www.machinesandwheels.com